

# INSTALLATION DIAGRAM 16 - 20 U

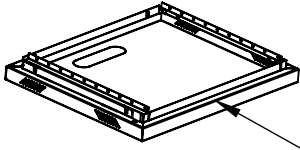

LOWER BASE FRONT SECTION

BOTTOM BASE IS PLACED ON A FLAT FLOOR

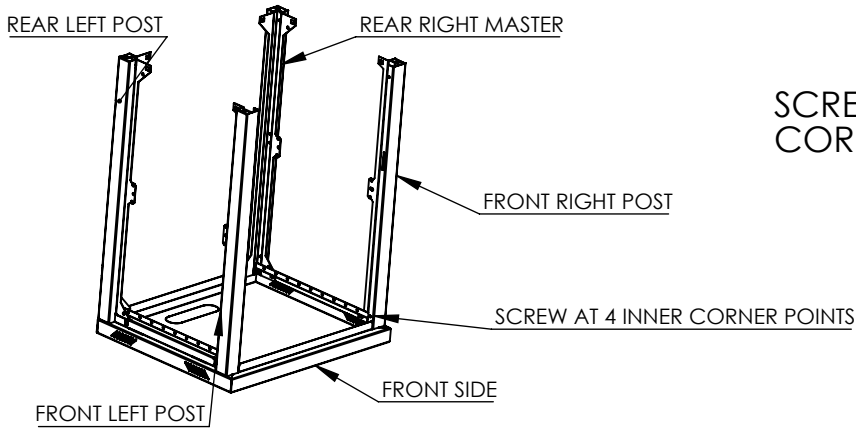

SCREW 4 POLES FROM ALL LOWER CORNERS TO THE BOTTOM BASE

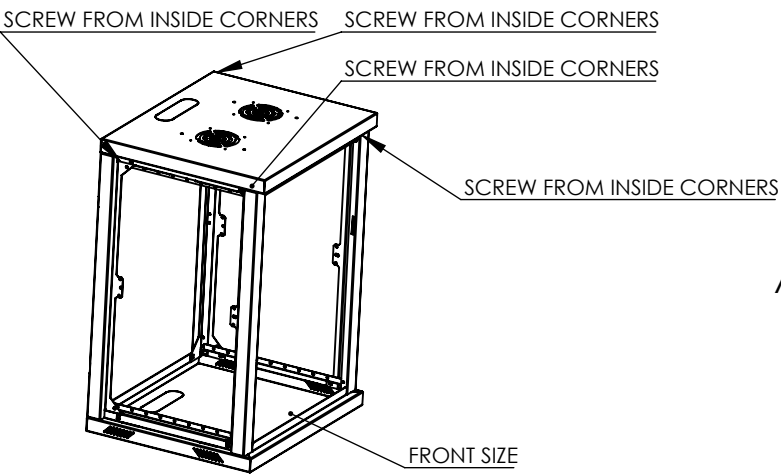

AFTER PLACING THE UPPER BASE, SCREW THE INSIDE CORNER

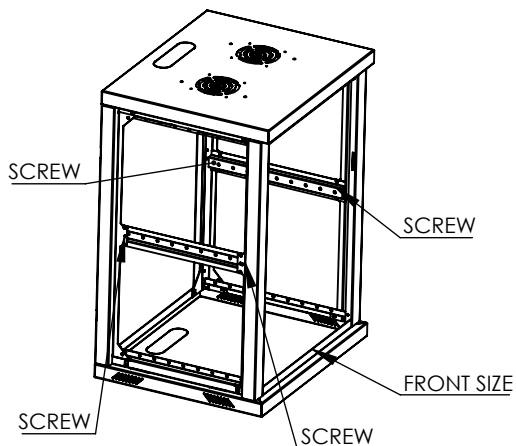

SCREW INSIDE HORIZONTAL CARRIER GALVANIZED PARTS

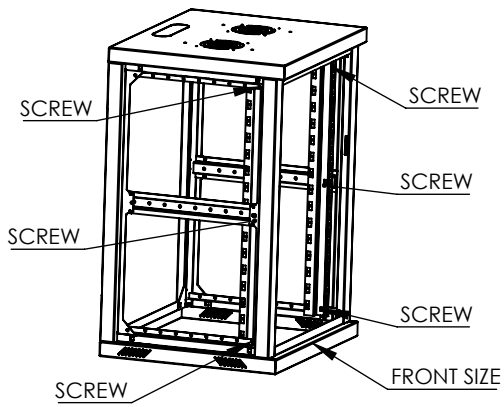

SCREW THE INNER GALVANIZED STRUT FROM THE OUTSIDE TO THE INSIDE.

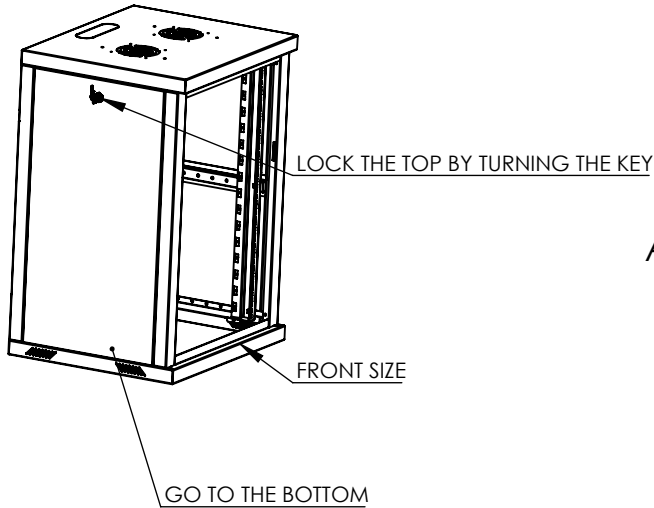

ASSEMBLE RIGHT AND LEFT SIDE DOORS BY LOCKING THEN FIRST AS SHOWN.

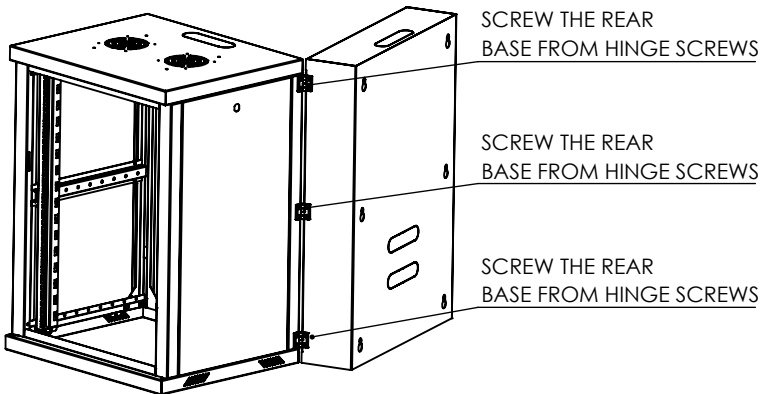

MOUNT THE REAR BASE TO THE CABIN BY SCREWING 3 HINGES

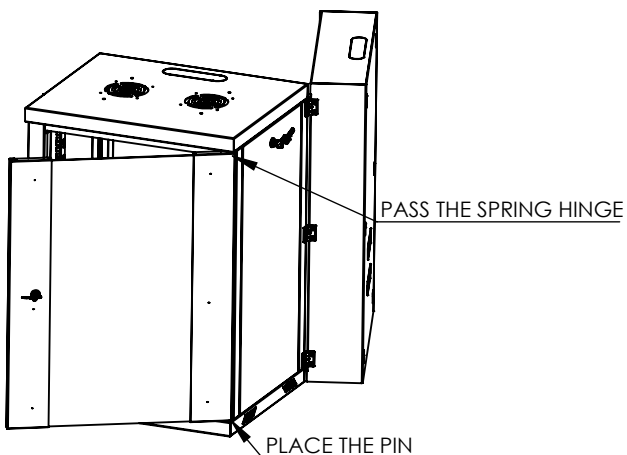

IT IS DONE AT THE DOOR ASSEMBLY, BY FINISHING THE PIN FROM THE BOTTOM AND PLACING THE SPRING HINGE FROM THE TOP TO THE SOCKET, AND THEN IT IS LOCKED WITH THE KEY

THUS, THE CABIN ASSEMBLY IS COMPLETED