



STEP 4

CAB BACK DOOR

CAB SIDE DOOR

CAB SIDE DOOR

REMOVE ALL CAB DOORS AND GET READY FOR INTERIOR PANEL ASSEMBLY

CAB BACK DOOR

CAB SIDE DOOR

CAB SIDE DOOR

STEP 5

SCREW THE TOP INTERIOR PANELS

SCREW THE MIDDLE INNER PANELS

SCREW ALL PANELS

SCREW BOTTOM INTERIOR PANELS

STEP 6

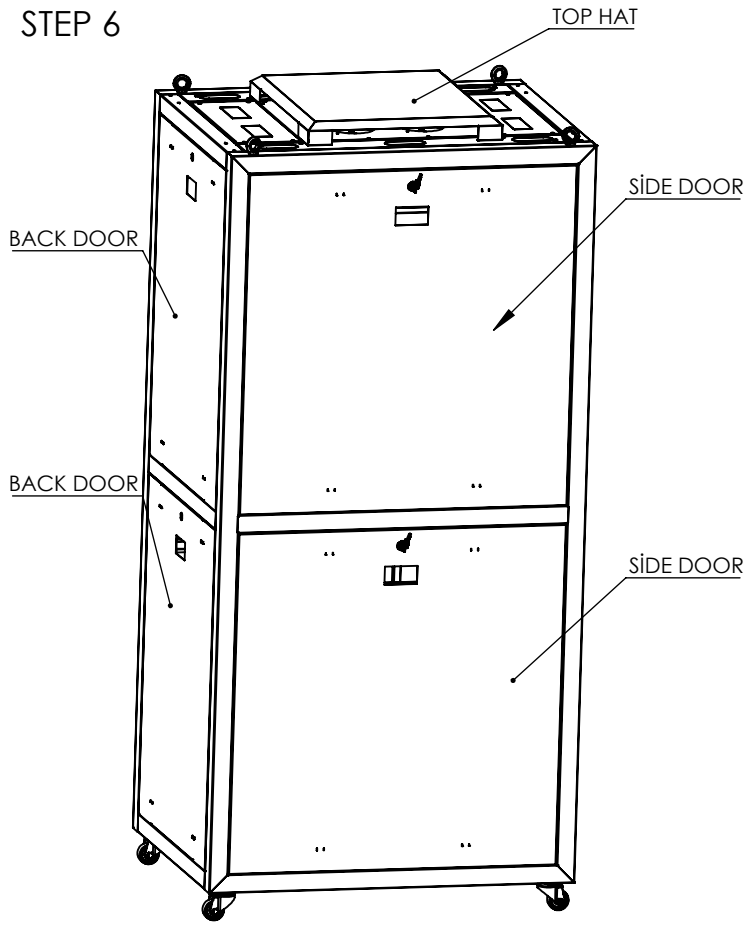

AFTER INSTALLING THE SIDE AND REAR DOORS IN PLACE, SCREW THE TOP CAP IN THE INSIDE AND 4 POINTS

STEP 7

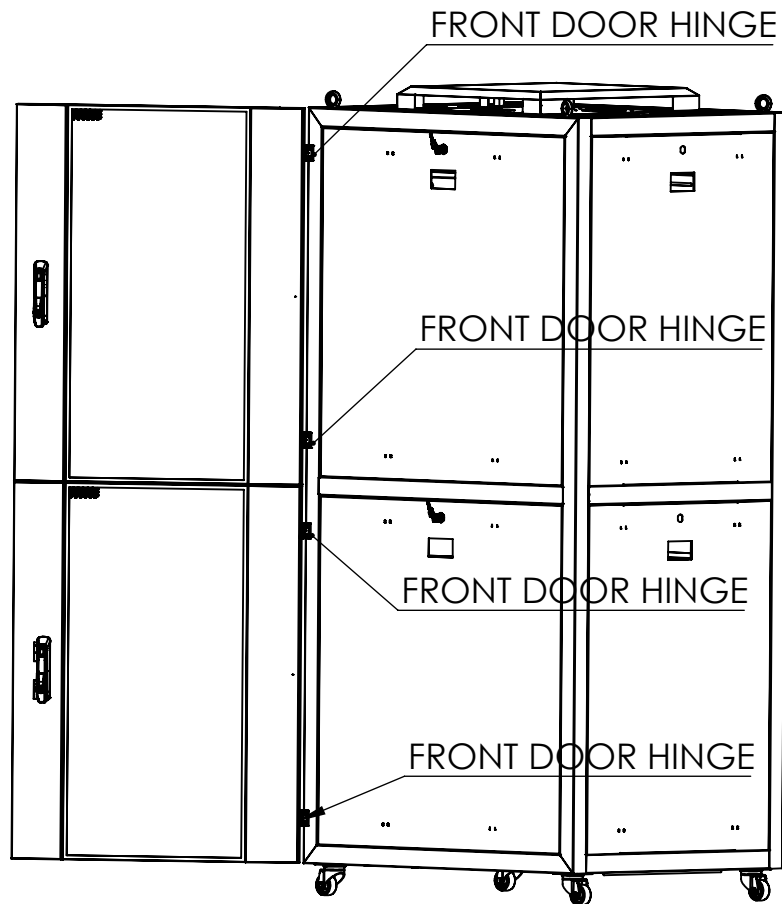

ASSEMBLE THE 2 FRONT DOORS FROM HINGES TO THE BODY

THUS, THE MOUNTING PROCESS IS COMPLETE